

**Bob  
AND  
Brad®**

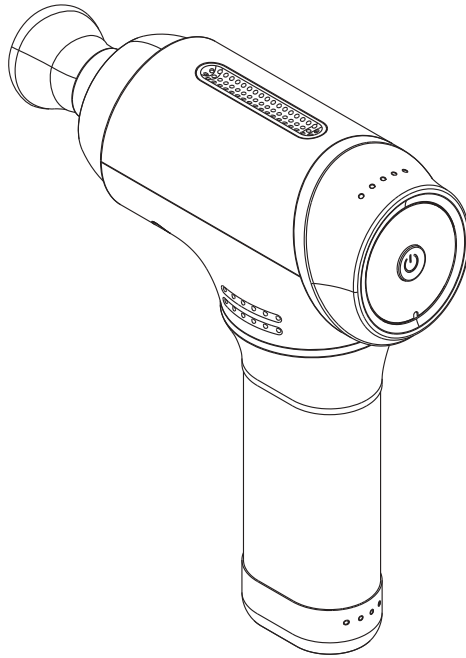

# **User Manual**

**QL/DMS.T2-C**  
Massage Gun

## Maintenance

---

The battery in this device is not designed to be removed or exchanged by the user. If there is any problem with the power supply, please contact us immediately.

**DO NOT** attempt to open or repair the device by taking it apart yourself. Tampering with the mechanics of the device in any way will result in an automatic voiding of the product's warranty.

## Warnings and Safety Precautions

---

Before connecting the device to the power supply, please ensure that the supply voltage stated on the rating plate is compatible with the unit.

Please charge the new batteries fully before the first use.

**DO NOT** submerge the device in water or any other liquid.

**DO NOT** use the device for more than 30 minutes at a time. Wait 5 minutes prior to using the device again, following a 30-minute session with the device.

**DO NOT** apply directly or around your head or genitals.

**DO NOT** use the device to supplement or replace any medical treatment. Please consult your physician before using the device if you are experiencing unexplained pain, receiving medical treatment, or using medical equipment.

**THIS PRODUCT IS NOT A MEDICAL PRODUCT.**

## FCC Statement

---

This device complies with Part-15 of the FCC Rules. Operation is subject to the following two conditions:

- (1) This device may not cause harmful interference.
- (2) This device must accept any interference received, including interference that may cause undesired operation.

## FCC Statement NOTE:

---

This equipment has been tested and found to comply with the limits for a Class B digital device, pursuant to Part 15 of the FCC Rules. These limits are designed to provide reasonable protection against harmful interference in residential installation. This equipment generates, uses, and can radiate

radio frequency energy, if not installed and used in accordance with the instructions. However, there is no guarantee that interference will not occur in a particular installation. If this equipment does cause any harmful interference to radio or television reception, which can be determined by turning the equipment off and on, the user is encouraged to try to correct the interference by one or more of the following measures:

- Reorient or relocate the receiving antenna.
- Increase the separation between the equipment and the receiver.
- Plug the equipment into the outlet on a circuit different from that to which the receiver is connected.
- Consult the dealer or an experienced radio/TV technician for help with the supplied fastener.

**DO NOT** hang the unit by the power cord.

## Disclaimer

---

Please contact your physician before using the **Bob and Brad QL/DMS.T2-C Massage Gun** if you have any physical health concerns or have any of the following conditions:

pregnancy, diabetes, epilepsy, migraines, herniated disks, spondylolisthesis, recent joint replacements or IUDs. Please also contact your physician before use if you have undergone recent surgery or have any metal pins or plates in your body.

## Contact Us

---

Web: [www.bobandbrad.com](http://www.bobandbrad.com)

Email: [support@bobandbrad.com](mailto:support@bobandbrad.com)

Tel: +1 (612) 567-3035

M-F 9:00AM-5:30PM

## WEEE Instructions

Correct Disposal of this product	
	<p>This marking indicates that this product should not be disposed with other household wastes throughout the EU. To prevent possible harm to the environment or human health from uncontrolled waste disposal, recycle it responsibly to promote the sustainable reuse of material resources. To return your used device, please use the return and collection systems or contact the retailer where the product was purchased. They can take this product for environmental safe recycling.</p>

## Battery Instructions

- ❶ **Do not** submerge the product into water or get it wet.
- ❷ **Do not** charge the product near an open flame or in any extremely hot conditions.
- ❸ **Do not** use or store the product near heat sources like furnaces or heaters.
- ❹ If the battery leaks or emits an odor, remove it immediately from close proximity to an open flame.
- ❺ **Do not** put the product into a fire or heat it up in any way.
- ❻ **Do not** disassemble the battery in any way.
- ❼ **Do not** use the product if, while the battery is in use or charging, it emits an odor; gives off excessive heat; shows signs of deformation, discoloration, or any other abnormalities. If the battery is in use or being charged, disconnect the battery from the power source.
- ❽ Charge for about three hours before its first use to a full charge. The device can be connected or disconnected.
- ❾ Connect the output end of the connection cable to the bottom of the massage instrument's DC charging port. Then, connect the input end of the connection cable to a mobile power adapter or cell phone charger (5V 2A; if less than 2A, the charging time will be longer).
- ❿ The power indicator light will flash regularly, indicating that the battery is being charged.

## RoHS Declaration

Our product is compliant with RoHS 2.0 (2011/65/EU Directive) regarding restriction of hazardous substances and raw materials, and components of our product meet the following toxic and hazardous substance limits.

Cadmium (Cd): < 1000 ppm	Lead (Pb): < 1000 ppm
Mercury (Hg): < 1000 ppm	Hexavalent Chromium: (Cr VI) < 1000 ppm
Polybrominated Biphenyls (PBB): < 1000 ppm	Polybrominated Diphenyl Ethers (PBDE): < 1000 ppm
Bis(2-Ethylhexyl) phthalate (DEHP): < 1000 ppm	Benzyl butyl phthalate (BBP): < 1000 ppm
Dibutyl phthalate (DBP): < 1000 ppm	Diisobutyl phthalate (DIBP): < 1000 ppm

# Main Structure and Fittings

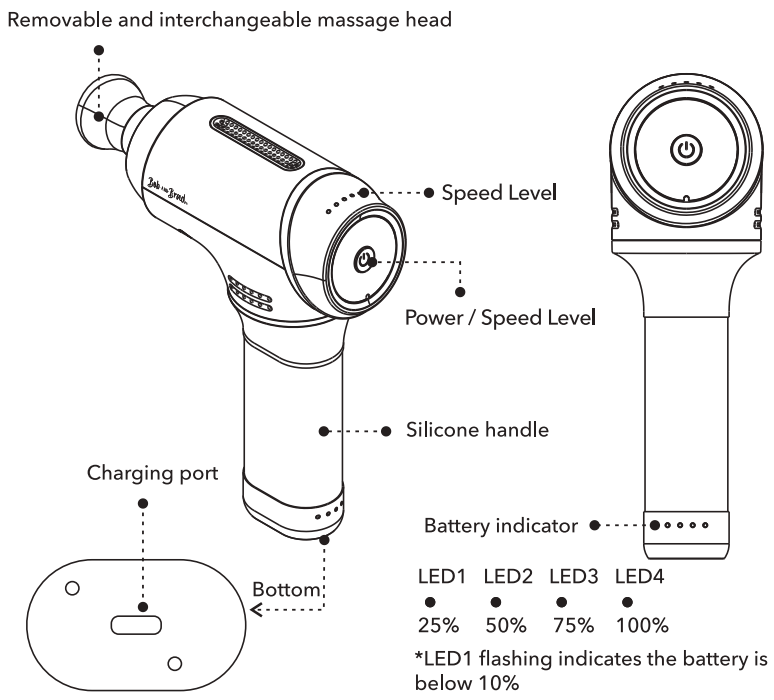

**Ball head**  
For large muscle groups like quads, glutes, extreme muscles, and joint soreness.



**U-shaped head**  
For spine, neck, and shoulder for sensitive muscles and soft tissues.



**Air cushion head**  
For sensitive body parts relaxation.



**Flat head**  
For all parts of the body.



**Bullet head**  
For joints, deep tissues, trigger points and small muscle areas like feet and wrists.



**Rubber Sleeve**  
Each massage head is pre-installed with a rubber sleeve. If it is damaged, replace it with the spare one.

## Operation Steps

---

1. Connect the massage head to the device when the device is powered off. Insert the massage head completely with pressure and ensure the head is correctly positioned and the buckle is inserted into the slot. (Note: The U-shaped head should be positioned for installation. When the buckle is inserted into the slot, the installation is in place. If the massage head is not installed in place, there will be a risk of falling out while in use.) To remove a massage head, simply turn off the device and pull out the interchangeable massage head.

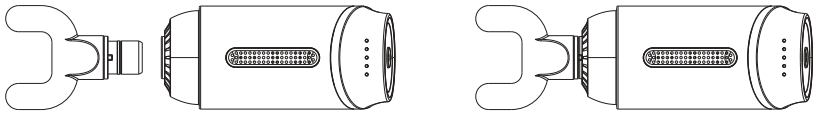

2. In the shutdown state, long press the "⏻" button on the panel for 2 seconds to turn on and start the first speed. Promptly press the "⏻" button on the panel to switch speeds between levels 0-5. When the device is running in levels 1-5, press the "⏻" button and return to the level 0 position for 2 seconds to stop the output. Long press the "⏻" button for 2 seconds while the device is in level 0 to shut down the device.
  - After 10 minutes of operation, the device automatically turns off.
  - LED lights indicate the corresponding strike frequency level from lowest (level 1) to highest (level 5).
  - When the device is on standby (level 0), it will automatically shut down after 20 seconds of inactivity.
3. Apply the required pressure at each preset vibration frequency to massage target muscle groups.

## Battery display

---

LED1	LED2	LED3	LED4
●	●	●	●
25%	50%	75%	100%

\*LED1 flashing indicates the battery is below 10%

When the first indicator light (LED1) is on: 25% of the battery remains.

When the second indicator light (LED2) is on: 50% of the battery remains.

When the third indicator light (LED3) is on: 75% of the battery remains.

When the fourth indicator light (LED4) is on: 100% of the battery remains.

#### Note:

1. When the first indicator light (LED1) flashes, the battery power is below 10% and requires recharging.
2. It is not recommended that the battery power be depleted below 25%.

## About Charging

---

- Before the first use, please fully charge the device using the USB-A/ USB-C to USB-C cable that comes with the massage gun. A full charge takes about 3 hours.
- Connect the output end of the connection line to the DC charging port at the bottom of the device. Then connect the input end of the connection line to the mobile power source or mobile adapter for outlets (5V/2A; if the charging current or voltage is less than 5V/2A, charging time will be longer. Any regular phone adapter will be able to charge the massage gun without a problem).
- The battery can be recharged at any level of battery power. When charging the battery, please ensure that the device is shut down. When the device is in operation, the charging will be automatically stopped.
- When the battery icon on the handle stops flickering and remains on, the light display shows that 100% of the battery is full.
- The battery can be recharged at any level of battery power. When charging, please ensure that the device is shut down. When the device is in operation, the charging will be automatically protected.
- When the first indicator light is flashing, the battery power is below 10% and requires recharging.
- It is not recommended that the battery power be depleted to below 25%.
- The average working time with a full charge is about 3 hours. However, this varies depending on vibration frequency and massage pressure during use.

## Technical Details:

---

- Product Name: Massage Gun
- Product Model: QL/DMS.T2-C
- Speed: 2000-3200 r/min
- Rated Power: 25W
- Dimensions: 5.4"x2.4"x7.6"
- Rated Voltage: 7.3V  $\text{=}$
- Battery Capacity: 4000mAh / 29.2Wh
- Charging Time: 270 minutes

## Guarantee

---

This product comes with a **one-year warranty** from the date of purchase.

Warranty will be voided due to any of the following:

- Damaged due to improper usage or storage.
- Damaged by attempting to repair or disassemble the device.
- Period of warranty exceeded.

## IC Warning

---

This device contains licence-exempt transmitter(s)/receiver(s) that comply with Innovation, Science and Economic Development Canada's licence-exempt RSS(s). Operation is subject to the following two conditions:

- (1) This device may not cause interference.
- (2) This device must accept any interference, including interference that may cause undesired operation of the device.



## Using Massage Gun

### 1. Important tips before use

#### 1.1 Charging

- Please charge the massage gun before use.
- To charge the massage gun, plug the type C cable into an adapter and into the unit's charging interface.
- The indicator light on the massage gun will **BLINK BLUE** during the charging process. The indicator light will be **SOLID BLUE** when charging is complete.
- For safety considerations, the massage gun will NOT work while charging the battery. Additionally, the massage gun will automatically shut off after 10 minutes of continuous use. If you want longer massage, please turn it on again.



**DON'T** use the massage gun when charging the battery!

## Troubleshooting

PROBLEM	CAUSE	SOLUTION
Massage gun doesn't turn on.	Power is off.	Long press the Power Button to turn on the massage gun.
	Battery is too low.	Charge the massage gun.
	Massage gun shuts-off after 10 minutes.	Long press the Power Button to turn on the massage gun for another 10 minutes.
Massage gun shuts off automatically.	The massage gun's overheat protection will switch off the massage gun automatically when too hot.	Wait for the massage gun to cool down before powering it back on.
	Massage gun shuts-off after 10 minutes of use.	Long press the Power Button to turn on the massage gun for another 10 minutes.
Massage gun fails to run.	The massage head is too inserted too tight.	Plug out the massage head a little, then power it on.
If you encounter any other problems, contact: <a href="mailto:support@bobandbrad.com">support@bobandbrad.com</a>		

Utilize the Bob and Brad massage gun before, during, or after your workout for maximum benefits. This massage gun can help accelerate muscle tissue responsiveness by increasing hydration, range of motion, and function to tight muscles.

<b>Indication</b>	<b>Action</b>	<b>Speed</b>	<b>Pressure</b>	<b>Duration</b>	<b>Muscle Position</b>	<b>Movement</b>
Warm Up/ Activation	Activate and prime muscles prior to exercise. Reduce risk of injury.	Level 3	Light to Moderate	30 sec or less	Relaxed. Move along the muscle.	Quick, high speed over area.
Mid Workout / Myofascial Mobility	Help muscle recovery and reactivation.	Level 4	Heavy (especially for large muscle groups)	8-12 sec	Target specific area.	Localized
Recovery	Relax muscles and aid recovery.	Level 1 or 2	Moderate to Heavy	90 sec or more	Move along the muscle.	Slow movement along the muscle
Pain Modulation	Reduction in pain to increase movement.	Level 3	Light	10 to 30 sec	Relaxed. Localised spot.	Over painful areas.
Body Awareness	Improve movement or mechanics of a joint. Activation of a muscle. Draw attention to a muscle	All Levels	Light to Moderate	10 to 20 sec	Relaxed or with movement	Over specific target area or movement over area.

# CHEST

2 Minutes

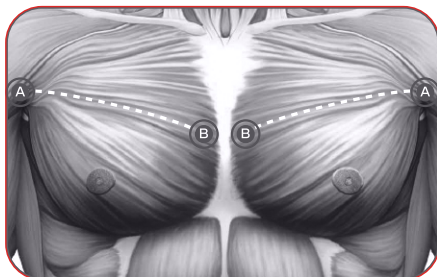

ATTACHMENT: **BALL HEAD**  
PROTOCOL: **Sweep from A to B on each side for 1 minute**  
DURATION: **2 minutes**

---

# ABS

2 Minutes

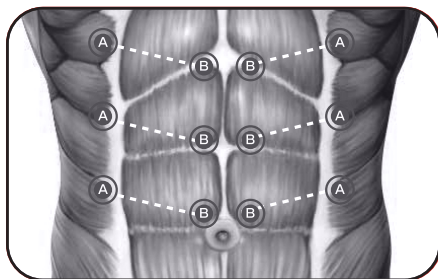

ATTACHMENT: **BALL HEAD**  
PROTOCOL: **Sweep from A to B on each side for 1 minute**  
DURATION: **2 minutes**

# UPPER BACK

4 Minutes

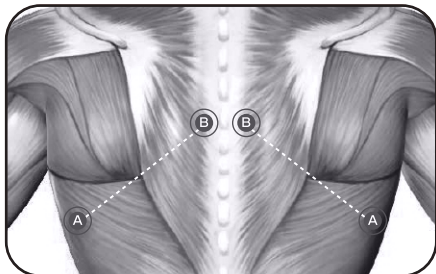

ATTACHMENT: **BALL HEAD**

STEP 1: **Upper back**

PROTOCOL: **Sweep from A to B on each side for 1 minute**

DURATION: **2 minutes**

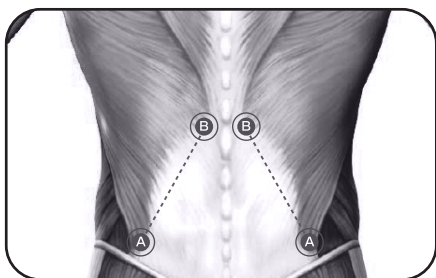

STEP 2: **Lower back**

PROTOCOL: **Sweep from A to B on each side for 1 minute**

DURATION: **2 minutes**

# SHOULDERS

2 Minutes

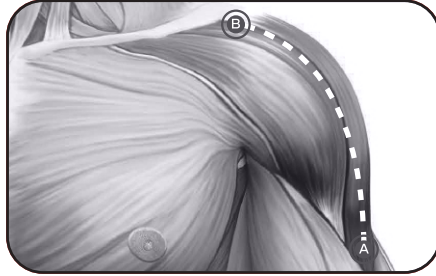

ATTACHMENT: **BALL HEAD**  
PROTOCOL: **Sweep from A to B on each side for 1 minute**  
DURATION: **2 minutes**

---

# BICEPS

2 Minutes

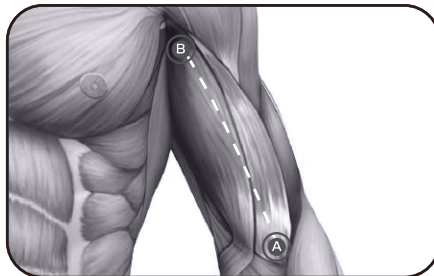

ATTACHMENT: **BALL HEAD**  
PROTOCOL: **Sweep from A to B on each side for 1 minute**  
DURATION: **2 minutes**

# TRICEPS

4 Minutes

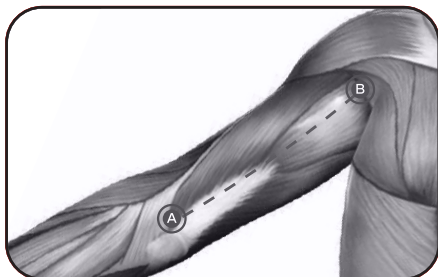

ATTACHMENT: **BALL HEAD**

PROTOCOL: **Sweep from A to B on each side for 2 minutes**

DURATION: **4 minutes**

---

# FOREARM

2 Minutes

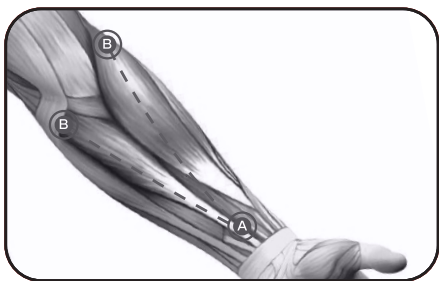

ATTACHMENT: **BALL HEAD**

PROTOCOL: **Sweep from A to B on each side for 1 minute**

DURATION: **2 minutes**

# HANDS

1 Minute

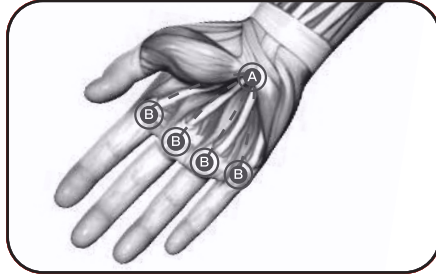

ATTACHMENT: **BALL HEAD**

PROTOCOL: **Sweep from A to B on each side for 30 seconds**

DURATION: **1 minutes**

---

# HIP FLEXORS

2 Minutes

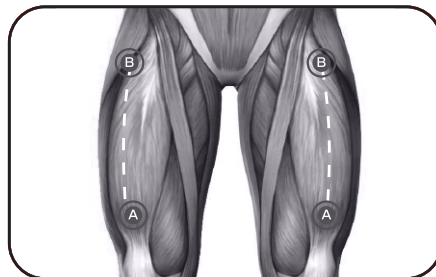

ATTACHMENT: **BALL HEAD**

PROTOCOL: **Sweep from A to B on each side for 1 minute**

DURATION: **2 minutes**

# SHINS

1 Minute



ATTACHMENT: **BALL HEAD**  
PROTOCOL: **Sweep from A to B on each side for 30 seconds**  
DURATION: **1 minute**

---

# GLUTES

4 Minutes

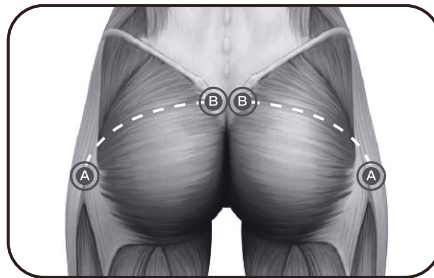

ATTACHMENT: **FLAT HEAD**  
PROTOCOL: **Sweep from A to B on each side for 2 minutes**  
DURATION: **4 minutes**



# HAMSTRINGS

2 Minutes

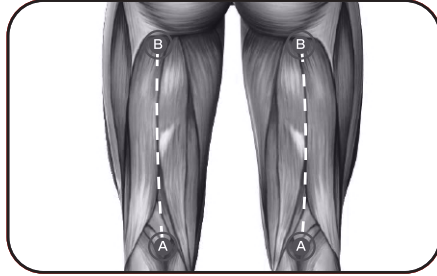

ATTACHMENT: **BALL HEAD**

PROTOCOL: **Sweep from A to B on each side for 1 minute**

DURATION: **2 minutes**

---

# CALVES

2 Minutes

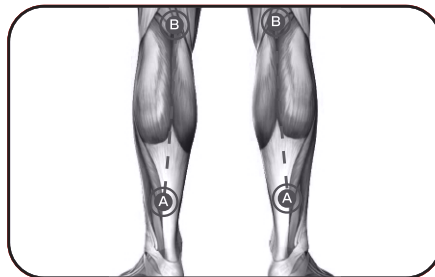

ATTACHMENT: **BALL HEAD**

PROTOCOL: **Sweep from A to B on each side for 1 minute**

DURATION: **2 minutes**

# FEET

4 Minutes



ATTACHMENT: **BALL HEAD**

PROTOCOL: **Sweep from A to B on each side for 2 minutes**

DURATION: **4 minutes**

## A Dedicated Team Just For You



Every Bob and Brad product is backed by a 1-year warranty and an award-winning customer service team. If you are in any way dissatisfied with a product you ordered, we'll exchange it, replace it or refund your money under the warranty. Simply email us the problem, and we'll take care of it.



### Troubleshoot

Help you solve any issues with your device.



### Product Knowledge

Answer questions about your device and best practices.



### Initiate Returns

Provide instructions for replacements, returns and refunds.



### Place New Orders

Help with placing orders online and/or authorized resellers.

### Get in Touch.

Call: +1 (612) 567-3035 Mon-Fri 9:00AM-4:30PM (CST)

Email: [support@bobandbrad.com](mailto:support@bobandbrad.com)

FLIGE Products LLC

3001 Esperanza Crossing Austin, TX 78758



